

FLUSHING RINGS

FR SERIES

FR series for flange type can be mounted between the process connection and the diaphragm seal for flushing or venting the space in front of the membrane of the diaphragm seal. The two flushing ports allow to wash out particles accumulated in front of the membrane, and the pressure space can be vented.

Technical Data

Body material: SS316; option available

Flushing Connection: 2 x ½" or ¼" NPT; other nominal sizes upon request

Plug Screws: 2 x ½" or ¼" NPT, SS316 for the flusing connection

Process Connection:

For flanges per EN1092-1 with sealing face B1 – DN25,40,50,80,100,125, PN16...100

For flanges per ASME with sealing face ASME B16.5 RF – NSP ¾", 1", 1½", 2", 3", 4", 5", Class 150...600

Other forms of flange, or other forms sealing face on request.

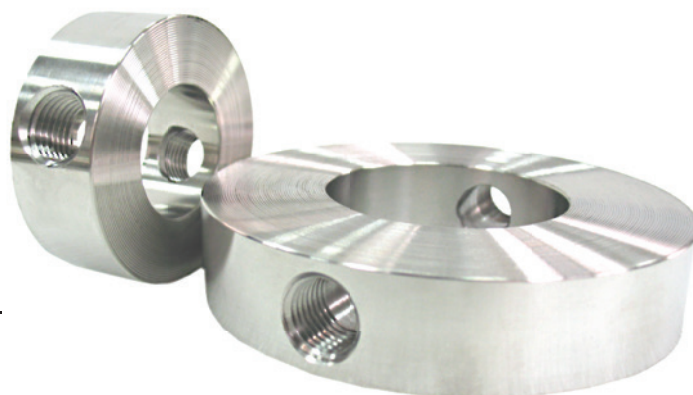

Approvals:



Dimensions-mm

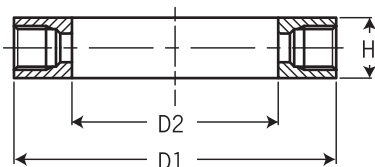

Per EN 1092-1

Connection Size		Dimensions			
DN	Class	D1	D2	H(½")	H(¼")
25	16...600	68	34	30	19
40	16...600	88	42	30	19
50	16...600	102	62	30	19
80	16...600	138	92	30	19
100	16...600	162	92	30	19
125	16...600	188	126	30	19

Per ASME B16.5

Connection Size		Dimensions			
NSP	Class	D1	D2	H(½")	H(¼")
¾"	16...600	60.0	27	30	19
1"	16...600	63.5	34	30	19
1½"	16...600	73.0	42	30	19
2"	16...600	92.0	62	30	19
3"	16...600	127.0	92	30	19
4"	16...600	157.0	92	30	19
5"	16...600	185.5	126	30	19

Parts List

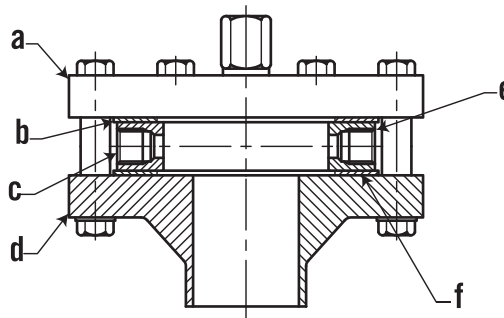

Item	Description of Parts
a.	Diaphragm Seal Flange
b.	Sealing
c.	Flushing Connection ½"NPT
d.	Process Flange
e.	Flushing Ring
f.	Sealing

Ordering Information

FR	Code	Body Material				
	S	SS316	0	Option		
		Code	Flushing Connection (part C)			
		A	½"NPT	B	¼"NPT	O Option
		Code	Process Connection			
		DN	(3) 25 (5) 40 (6) 50 (7) 80 (8) 100 (9) 125			
		NSP	(10) ¾" (11) 1" (13) 1½" (14) 2" (15) 3" (16) 4" (17) 5"			
		Code	Flange Rating			
			(1) 150# (2) 300# (3) 400# (4) 600# (5) PN16 (6) PN25 (7) PN40 (8) PN64 (9) PN100			
FR						Complete Ordering Code