

FLOW SIGHT GLASS GAUGE

NAW-1 – WITH TEFLON BALL

NAW-2 – WITH ROTOR

Technical Data

Service: for Gases and Liquid

Wetted Parts Material:

Body: SS316, PP or PVDF available

Ball: Teflon

Window: Tempered glass

Gasket: Viton or EPDM

Rotor: PP+10% glass fiber (Color/Orange; Temp.: -20~80°C)

PVDF (Color/White; Temp.: -20~90°C)

PPS (Color/Yellow; Temp.: -20~200°C)

Rotor Guide: SS316, or Ceramic available

Temperature Limit:

• SS316 Body with Viton Gasket : (-15°C) ~ +200°C

• SS316 Body with EPDM Gasket : (-20°C) ~ +120°C

• PP Body with Viton or EPDM Gasket : 0 ~ 60°C

• PVDF Body with Viton Gasket : (-15°C) ~ +90°C

• PVDF Body with EPDM Gasket : (-20°C) ~ +90°C

Pressure Limit:

• Metal: 16 bar • Plastic (PP): 8 bar • Plastic (PVDF): 10 bar

Connection: Threaded type

Size: Thread 1/4", 3/8", 1/2", 3/4", 1", 1 1/4", 1 1/2" NPT or BSP female available

Flow Direction: NAW-1: Left to Right or Right to Left available
NAW-2: Any direction available

Flow Range Table

NAW-1 : With Teflon Ball

Size	1/4"	3/8"	1/2"	3/4"	1"	1 1/4"	1 1/2"
Min. Flow (LPH) Water	24	35	290	880	750	900	950
Min. Flow (NLPM) Air	6.9	11.3	111.8	263.9	222.2	500	555.6
ΔP (2m/sec) BAR	0.15	0.15	0.19	0.18	0.45	0.2	0.25

NAW-2 : With Rotor

Size	1/4"	3/8"	1/2"	3/4"	1"
Min. Flow (LPH) Water	192	194	203	250	400
Min. Flow (NLPM) Air	23.6	19.7	27.8	120.8	138.9
ΔP (2m/sec) BAR	0.15	0.18	0.21	0.2	0.5

NOTE. The Flow Range Table is based on Water.

Dimensions

(A) **NAW-1**, With Teflon Ball

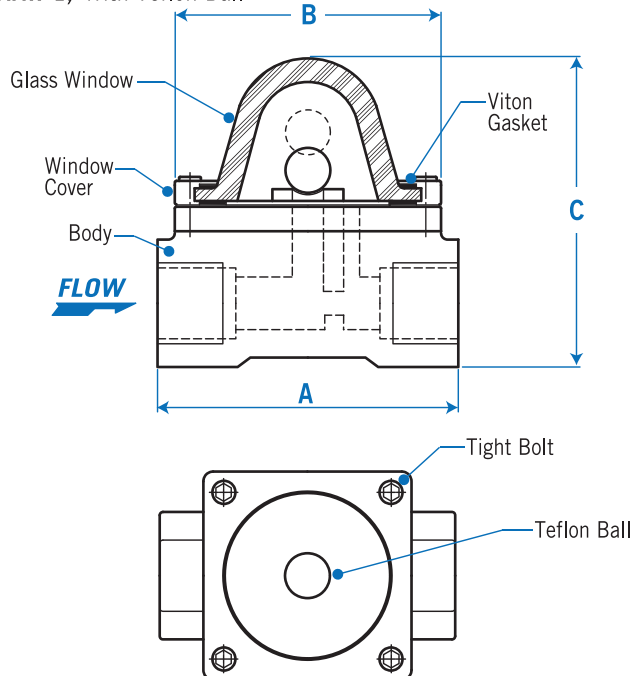

Dimensions Data-mm

Size	1/4"	3/8"	1/2"	3/4"	1"	1 1/4"	1 1/2"
A	76	76	76	89	89	117	117
B	63	63	63	63	63	75	75
C	79	79	79	95	95	125	125

Flow Direction Horizontal direction only.

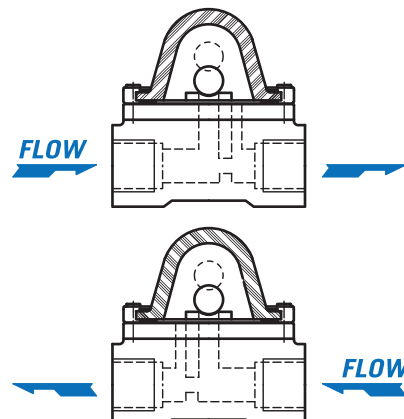

NAW-1



NAW-2



NAW-1 (Plastic)

NAW-2 (Plastic)

Approvals:



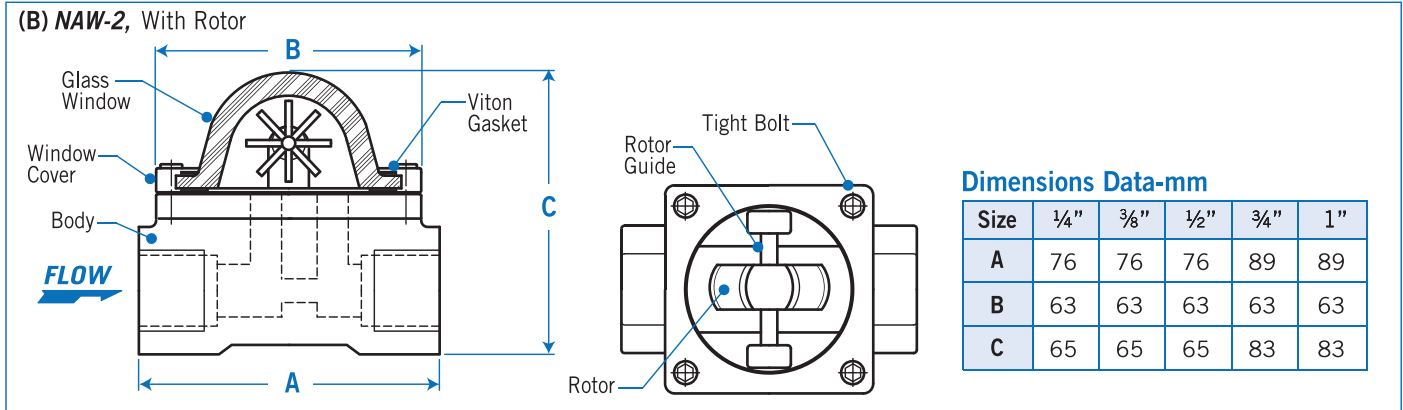

Flow Direction

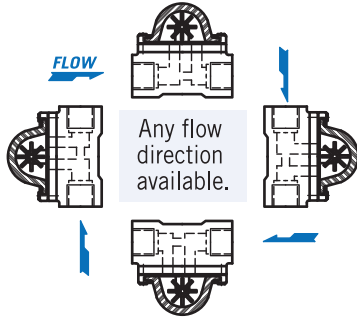

Optional for Rotors

POM Color: Orange Temp. Limit: 100°C	PP+10% Glass Fiber Color: Yellow Temp. Limit: 60°C	PPS+40% Glass Fiber Color: Dark Brown Temp. Limit: 200°C	PVDF Color: Red or White Temp. Limit: 100°C

NOTE. The temperature limit above-mentioned is only for the reference to the rotors. Please also considering the max. temperature of body in the operating.

Ordering Information

NAW-1 : With Teflon Ball

NAW	Code	Model
	1	Teflon Ball Type
		Code Material of Body / Ball
		S (S) SS316/Teflon Ball (P) PP/Teflon Ball (only for thread 1/4" to 1") (D) PVDF/Teflon Ball (only for thread 1/4" to 1")
		Code Gasket Material
		V Viton E EPDM O Option
		Code Connection Size (Female)
		(1) 1/4" (2) 3/8" (3) 1/2" (4) 3/4" (5) 1" (6) 1 1/4" (7) 1 1/2"
		Code Thread Type
		(1) NPT (2) BSP (3) Option
		Code CE 1128 Mark Request
		(1) With label sticker (2) With S.S nameplate (3) Stamp (4) Without
NAW	1	Complete Ordering Code

NAW-2 : With Rotor

NAW	Code	Model
	2	Rotor Type
		Code Material of Body / Rotor / Rotor Guide
		SG (Y) SS316 / PP+10% Glass Fiber (Yellow) / SS316
		SD (R) SS316 / PVDF (Red) / SS316 (W) SS316 / PVDF (White) / SS316
		SP (O) SS316 / POM (Orange) / SS316
		SF (B) SS316 / PPS+40% glass fiber (Dark Brown) / SS316
		PG (Y) PP / PP+10% Glass Fiber (Yellow) / Ceramic
		PD (R) PP / PVDF (Red) / Ceramic (W) PP / PVDF (White) / Ceramic
		DD (R) PVDF / PVDF (Red) / Ceramic (W) PVDF / PVDF (White) / Ceramic
		Code Gasket Material
		V Viton E EPDM O Option
		Code Connection Size (Female)
		(1) 1/4" (2) 3/8" (3) 1/2" (4) 3/4" (5) 1"
		Code Thread Type
		(1) NPT (2) BSP (3) Option
		Code CE 1128 Mark Request
		(1) With label sticker (2) With S.S nameplate (3) Stamp (4) Without
NAW	2	Complete Ordering Code