

2-PIECE FLANGED BALL VALVE

NH2FC150-NL – ANSI 150LB

NH2FPN16F4 – DIN PN16

NH2FPN40F4 – DIN PN40

– With ISO 5211 Mounting Pad

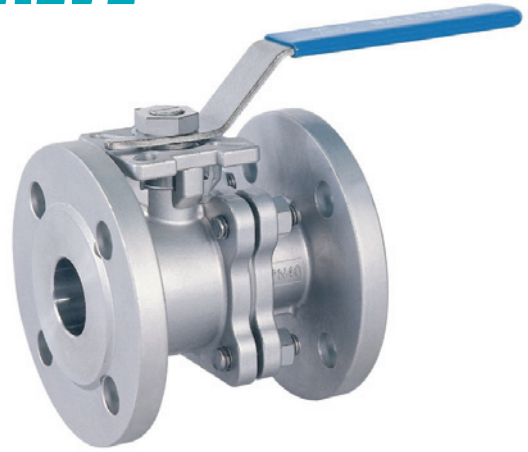

Technical Data

- ISO 5211 Direct Mounting Pad
- Full Port
- Fire Safe Design
- Valves Inspected & Tested according to API 598 Standard
- Investment Casting
- Design: ASME B16.34
- Material: ANSI 150LB– ASTM-A351-CF8M, ASTM-A351-CF8, ASTM-A351-CF3M, ASTM-A216-WCB

DIN PN16 & PN40– EN10213-1.4408, EN10213-1.4308, EN10213-1.4409, EN10213-1.0619

Working Pressure: ANSI Class 150 / DIN PN16 / DIN PN40

Flange Dimension: ANSI B16.5 / DIN 2543 / DIN 2545

Face to Face Dimension: ANSI B16.10 & DIN3202 / F4 Type

Size Ranging: ½”~4” (DN15~DN100)

Option: Locking Device

Dimensions

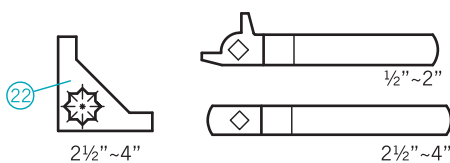
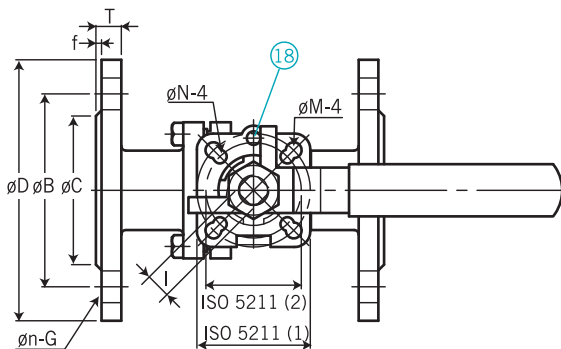
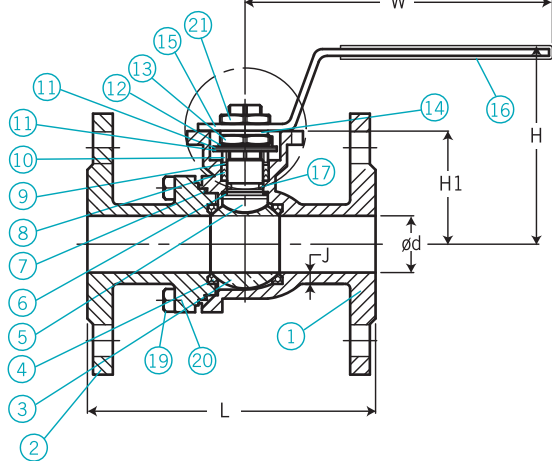

Dimension Data

SIZE	ød	L=F4			H	I	øB			øC			øM	øN	W
		ANSI 150	DIN PN16	DIN PN40			ANSI 150	DIN PN16	DIN PN40	ANSI 150	DIN PN16	DIN PN40			
		1/2"	15	108			115	115	76	9	60.5	65			
3/4"	20	117.5	120	120	78	9	70	75	75	43	58	58	6	6	111
1"	25	127	125	125	88	11	79.5	85	85	51	68	68	7	6	186
1 1/4"	32	140	130	130	94	11	89	100	100	63.5	78	78	7	6	186
1 1/2"	38	165	140	140	109	14	98.5	110	110	73	88	88	9	7	197
2"	50	178	151.5	151.5	117	14	120.5	125	125	92	102	102	9	7	197
2 1/2"	65	190.5	170	170	139	17	140	145	145	105	122	122	11	9	265.5
3"	80	203	182	182	149.5	17	152.5	160	160	127	138	138	11	9	265.5
4"	100	228.5	190	190	195	22	190.5	180	180	157	158	162	13	11	321

SIZE	øD			f			T			ISO 5211		øn		
	ANSI 150	DIN PN16	DIN PN40	ANSI 150	DIN PN16	DIN PN40	ANSI 150	DIN PN16	DIN PN40	(1)	(2)	ANSI 150	DIN PN16	DIN PN40
1/2"	89	95	95	1.6	2	2	11.2	16	16	F04 42	F03 36	15.9	14	14
3/4"	98	105	105	1.6	2	2	11.2	18	18	F04 42	F03 36	15.9	14	14
1"	108	115	115	1.6	2	2	11.2	18	18	F05 50	F04 42	15.9	14	14
1 1/4"	117	140	140	1.6	2	2	12.7	18	18	F05 50	F04 42	15.9	18	18
1 1/2"	127	150	150	1.6	3	3	14.3	18	18	F07 70	F05 50	15.9	18	18
2"	152	165	165	1.6	3	3	15.9	20	20	F07 70	F05 50	19.1	18	18
2 1/2"	178	185	185	1.6	3	3	17.5	18	22	F10 102	F07 70	19.1	18	18
3"	190	200	200	1.6	3	3	19	20	24	F10 102	F07 70	19.1	18	18
4"	229	220	235	1.6	3	3	23.8	20	24	F12 125	F10 102	19.1	18	22

SIZE	G			H1
	ANSI 150	DIN PN16	DIN PN40	
1/2"	4	4	4	39
3/4"	4	4	4	41
1"	4	4	4	50
1 1/4"	4	4	4	56
1 1/2"	4	4	4	70
2"	4	4	4	78
2 1/2"	4	4	8	98
3"	4	8	8	108.5
4"	8	8	8	140

